

If willing to print this file manually,  
please print to actual size  
100% (1:1), on thick paper  
min. 200 g/m<sup>2</sup>.  
Pink lines = the cut  
contour.

EVERSYS

DRILLING JIG

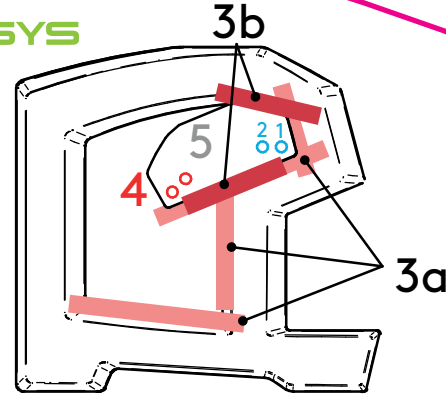
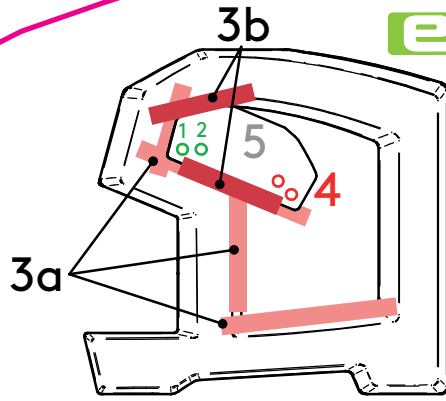

DRILLING JIG

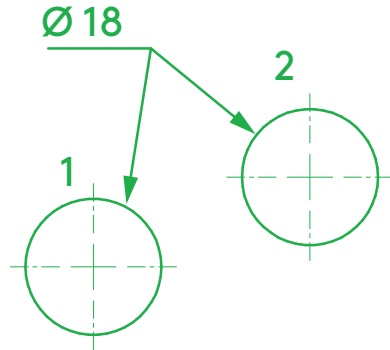

Right side holes

- Open the machine and remove either the steam module (right side) or the brewing module (left side).
  - Protect the machine with 4 x tape (3a) to avoid having metal chips falling in between the frame.
  - Place the DRILLING JIG (5) and tape it with some easy-to-tear paper (e.g. masking tape (3b)).
- Caution: Only drill both holes if you have two milk types.**

**Do NOT drill the red holes (4).**

- Punch the center of the hole(s).
- Drill the hole(s) to Ø 18 mm.
- Deburr the hole and clean the machine.
- Insert the rubber grommet(s), kit REF. 105 901.

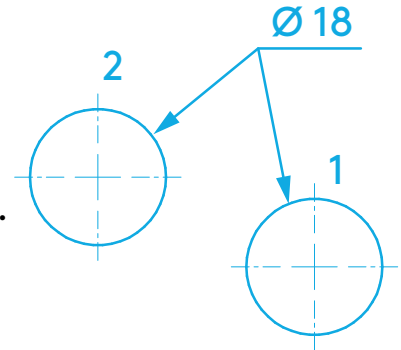

Left side holes